

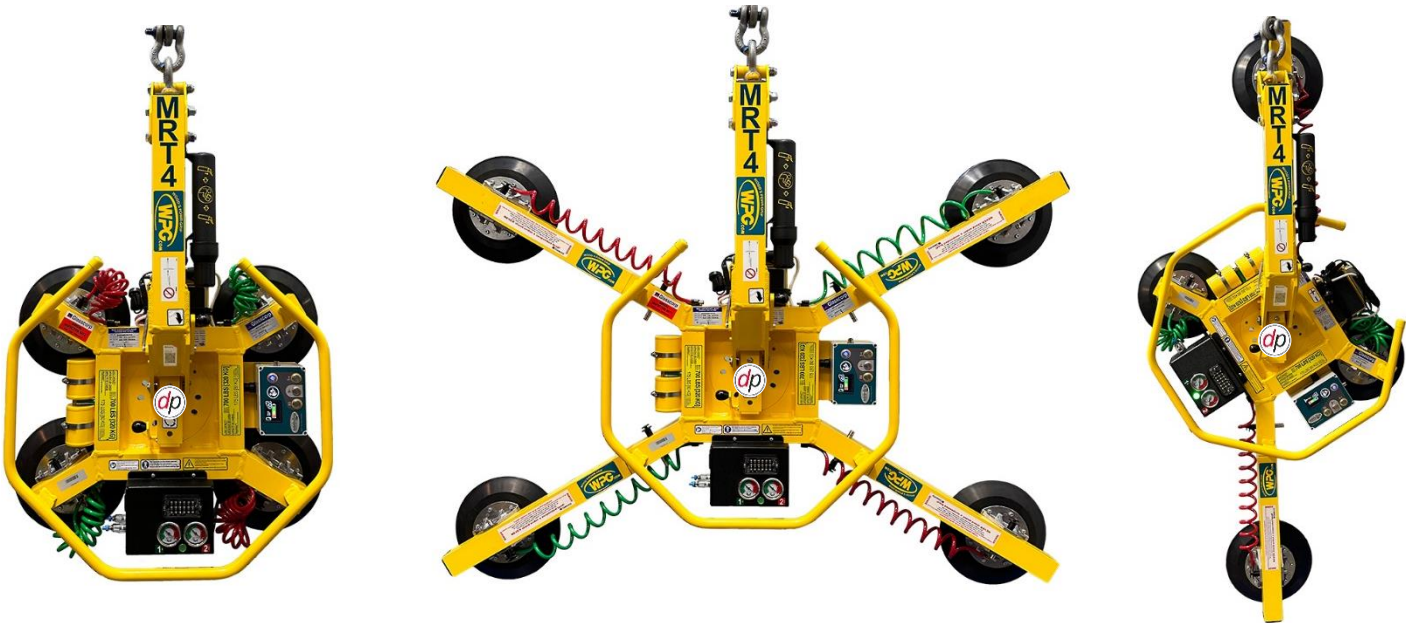

MRT4 DUAL CIRCUIT – VACUUM LIFTER (MAX CAPACITY 320KG)



MRT4 Dual Circuit [320kg]

The MRT4, with dual-circuit vacuum system technology for extra safety, is built for versatility. It delivers 360° rotation with 90° tilt from any rotation position. Using the extension arms and movable pads, three frame configurations are possible to cover most load sizes on site or in the workshop. A variable length lifting arm may be specified, allowing fitting under soffits and overhangs.

- Dual, independent vacuum circuits with two vacuum reserve tanks and two non-return valves
- Vacuum gauge for each circuit
- Manual 360° lockable rotation (continuous)
- Manual tilting from vertical to horizontal
- On-board maintenance-free vacuum pump
- 12v rechargeable battery with integral 110v or 240v charger and battery energy gauge
- Audio-visual low vacuum alert
- Four extension arms allow alternative configurations

NEED ADVICE?

We have experienced staff who can help you. We can visit your site to discuss your needs.

+44 (0) 1902 405553

- Fully Certified
- Max Lifting Capacity = 320kg
- Weight of Lifter = 58kg
- Operating Temperature = 0°C to 40°C
- Not Suitable in The Rain
- Use On Smooth, Flat, Non-Porous Surfaces

Applications

- ✓ GLASS
- ✓ SHEET METAL
- ✓ CERAMIC BOARDS
- ✓ ROOF / WALL PANELS





MRT4 DUAL CIRCUIT – VACUUM LIFTER (MAX CAPACITY 320KG)

Technical Data (mm)

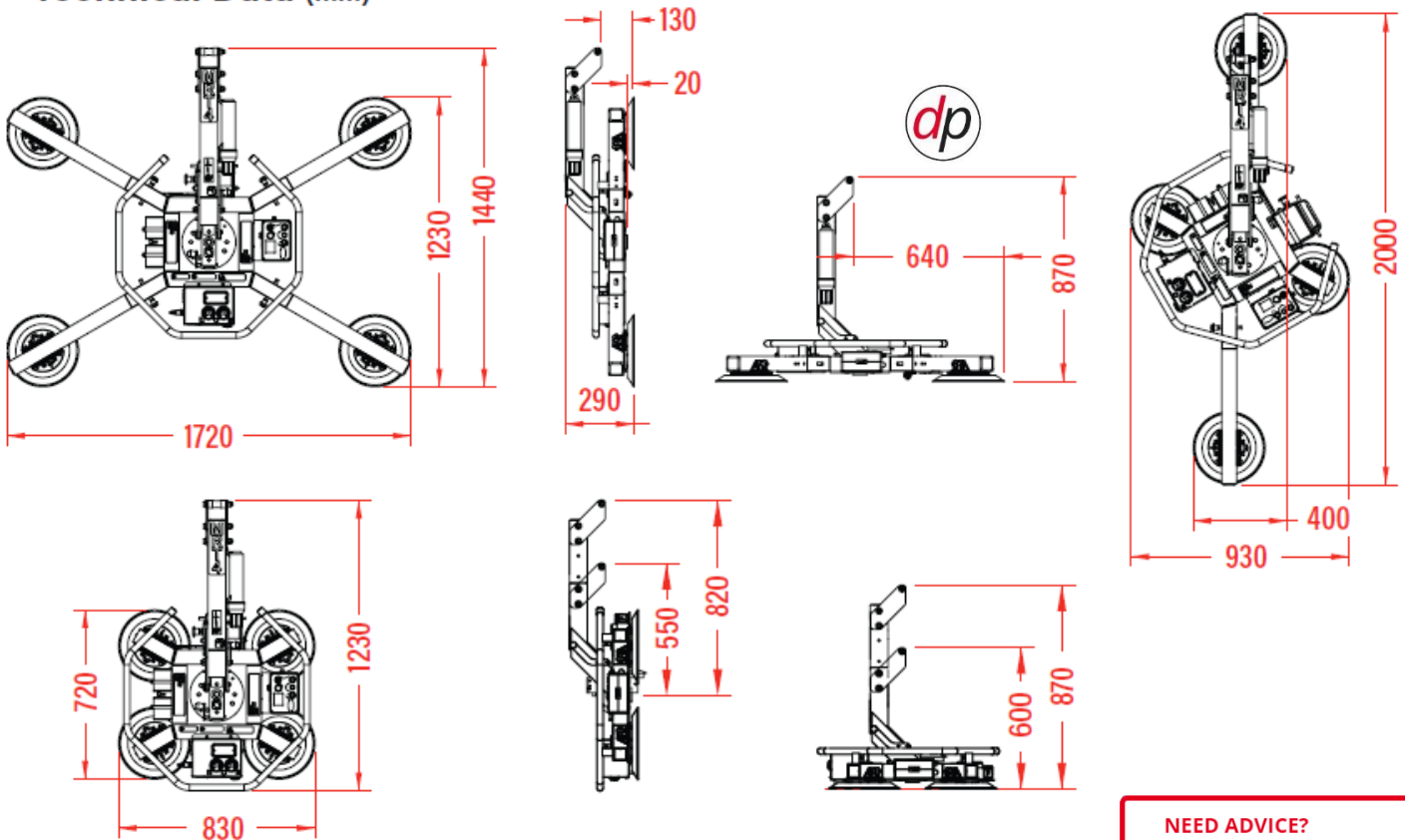

NEED ADVICE?
 We have experienced staff who can help you. We can visit your site to discuss your needs.
 +44 (0) 1902 405553

Technical Specifications

Safe working load (smooth, clean surface at 60% vacuum)	capacity:	320kg
Number of suction cups	cups:	4
Suction cup	description:	black rubber, not abrasion resistant
Suction cup diameter	approx diameter:	305mm
Suitable for lifting	material properties: surface: example:	gastight / non-porous smooth glass, plastic boards, ceramic plates, sheet metals, coated boards
Weight of lifter	approx:	58kg with extension arms, (42kg without arms)
Depth of lifter	depth:	290mm
Rotation	rotation:	360° manual continuous lockable positions
Tilt	tilt:	90° manual
Vacuum system	dual circuit:	1 pump, 2 vacuum reserve tanks
Voltage	pump: battery charger:	12v DC from rechargeable battery 110v/240v 50/60Hz single phase factory selectable
Standard accessories	standard	4 x extension arms
Optional accessories	optional:	variable length lifting arm, extra length extension arms, MRT Dolly curved pads (270kg capacity), stone pads (270kg capacity), radio remote, low marking pads, heat resistant pads, woods pad mount extensions